

FLO-GAGE™ 2-WIRE FLOW TRANSMITTER

Economical single package solution includes sensor and transmitter - suitable for liquids AND gases.

- Differential Pressure measuring principle avoids problems associated with sticking floats and plugging passages.
- Solid state strain gauge senses differential pressure directly.
- Low maintenance design with **no moving parts**
- Designed for use with computer control systems or remote readouts.
- Signal is proportional to flow rate squared (r^2). (Square root extraction is required in the receiving device.)
- Intrinsic safety option for Class I Div I, Groups A,B,C,D; Class II Div I, Groups E,F,G; EEx ia IIC T3.

Specifications

- See F-198 for general specifications
- Accuracy $\pm 3\%$ F.S. above 15% F.S.
- Ambient Temperature Limit 120 °F, 50 °C
- Current output 4-20 mA into 650 ohms max.
- Requires 24 vDC power supply (25 mA)
- Aluminum NEMA-4X / IP-66 enclosure



Ordering Information

- See F-198 for flow ranges and other ordering information.
- Select option W3.
- Append EM to model number for CE Mark labeling
- Append IS to model number for Intrinsic Safety labeling

RCM Industries, Inc.

110 Mason Circle, Concord, CA 94520
(925) 687-8363 Fax: (925) 671-9636
Toll Free: 888-flo-gage
<http://www.flo-gage.com>
email: info@flo-gage.com

Dimensions

Flo-Gage™ Option W3 Flow Transmitter

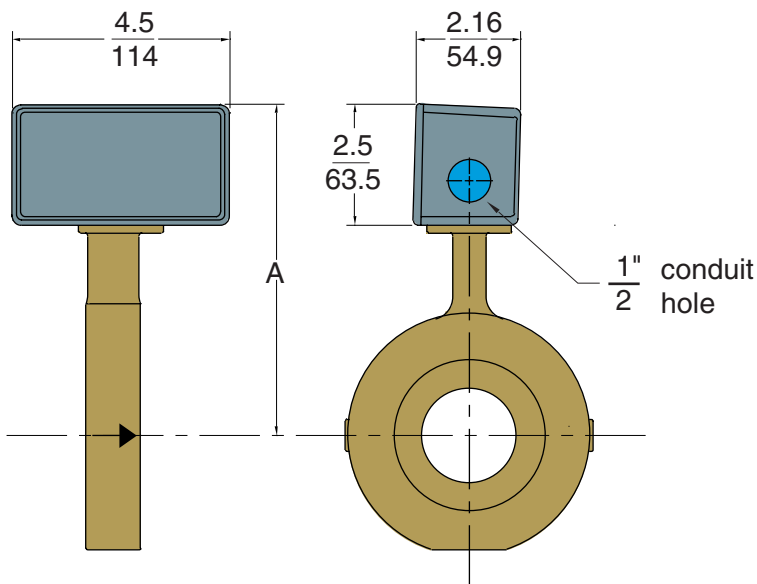
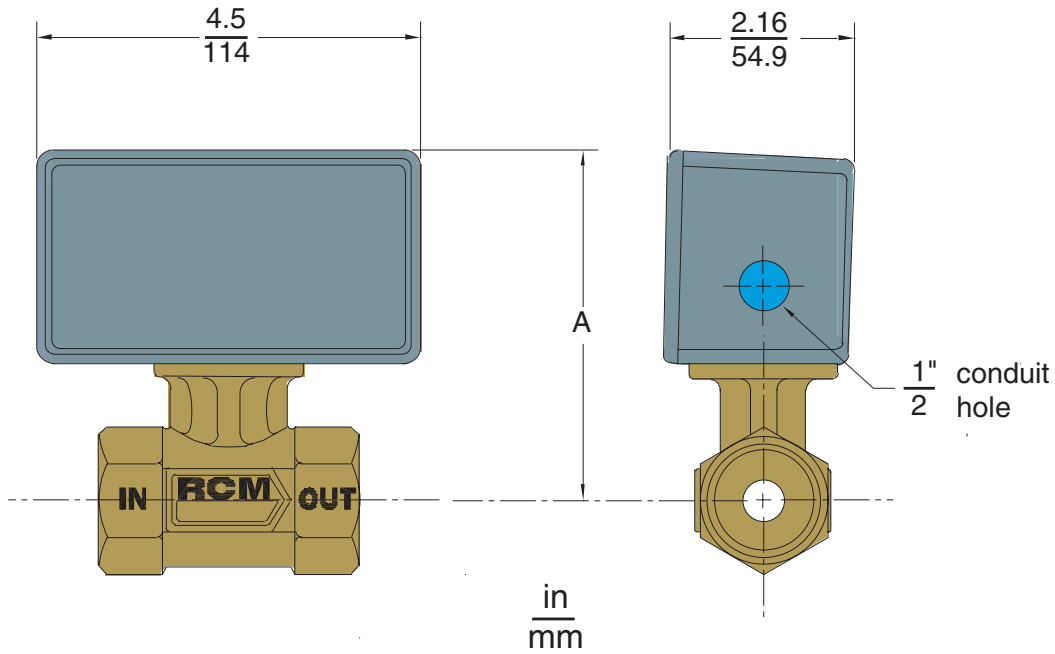

Pipe Size		Dimension A			
		Threaded		Wafer	
in	mm	in	mm	in	mm
0.25	08	3.20	81	n/a	n/a
0.50	15	3.20	81	4.62	117
0.75	20	3.95	100	5.06	129
1.0	25	4.07	103	5.25	133
1.5	40	4.39	112	5.81	148
2.0	50	4.80	122	6.00	152
2.5	65	n/a	n/a	6.54	166
3.0	80	5.48	139	6.87	175
4.0	100	n/a	n/a	7.95	202
5.0	125	n/a	n/a	8.36	212
6.0	150	n/a	n/a	9.05	230
8.0	200	n/a	n/a	10.30	262