

# RotorFlow - RFS Types Flow Setpoint Switching

ROTOR & TURBINE

RotorFlow Switches build an extra level of reliability and protection into your equipment. By principle of operation, the rotor cannot be deceived into indicating a positive flow situation when no flow actually exists. Once set to a desired actuation point, RotorFlow will switch to a 'no-flow' condition should the rotor stop for any reason.

## Specifications

<b>Wetted Materials</b>	Polypropylene, Brass, S Steel (Hydrolytically Stable, Glass Reinforced)	
<b>Body</b>	Ceramic	
<b>Rotor Pin</b>	Ryton Composite, Colour: Black	
<b>Rotor</b>	Polysulfone	
<b>Lens</b>	Buna N (Metal Body = Viton)	
<b>O-Ring</b>		
<b>Max. Operating Pressure</b>	Polypropylene Body:	7 bar
	Metal Body:	14 bar
<b>Max. Operating Temperature</b>	Polypropylene Body:	80 °C
	Metal Body:	100 °C
<b>Electronics</b>	65°C Ambient	
<b>Max. Viscosity</b>	45 cst	
<b>Input Power</b>	24 Vd.c. or 110 Va.c.	
<b>Relay Contact Ratings (SPDT)</b>	1A, 24 Vd.c. Resistive 0,5 A, 110 Va.c. (230 V a.c. on request)	
<b>Repeatability</b>	2% max. Deviation	
<b>Set Point Accuracy (Factory Set)</b>	± 5%	
<b>Hysteresis</b>	max. 15%	
<b>Electrical Termination</b>	22 AWG PVC-Jacketed Cable, Length 60 cm, Colour Code: Red = +Va.c./Vd.c., Black = Ground, White = N.O., Brown = N.C., Green = Common	
<b>Typical Pressure Drop:</b>	See Graphs	

## Switch Set Point Calibration With LED Signal (RFS Type)

With the unit installed in the line and power supplied, complete the following steps to calibrate switch actuation point with proper flow rate. A small flat-blade screwdriver is the only tool required.

1. Adjust liquid flow in the line to the rate at which switch actuation is desired.
2. Insert screwdriver into opening on backside of housing and fit blade into the potentiometer adjustment screw inside.
3. If LED is not illuminated, slowly turn screwdriver counterclockwise and stop as soon as LED illuminates.
4. If LED is illuminated, turn screwdriver clockwise until LED light goes out. Then, slowly turn screwdriver counterclockwise and stop as soon as LED illuminates.

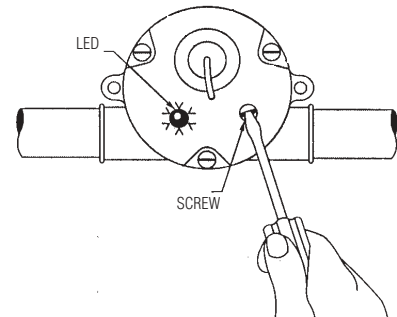

## How to Order

Body Material	Port Size	Flow Ranges (l/min)		Input Power	Order Number	
		Low Range*	Standard Range		BSP	NPT
Polypropylene	1/4"	0.4 to 4.0	2.0 to 20.0	24 VDC 110 VAC	<b>155425BSPP</b> 155876BSPP	155425 155876
	1/2"	6.0 to 45.0	15.0 to 75.0	24 VDC 110 VAC	<b>155485BSPP</b> 155886BSPP	155485 155886
Brass	1/4"	0.4 to 4.0	2.0 to 20.0	24 VDC 110 VAC	<b>156265BSPP</b> 156266BSPP	156265 156266
	1/2"	6.0 to 45.0	15.0 to 75.0	24 VDC 110 VAC	<b>156268BSPP</b> 156269BSPP	156268 156269
	3/4"	---	20 to 112.5	24 VDC 110 VAC	180395BSPP 180396BSPP	180395 180396
	1"	---	30 to 225	24 VDC 110 VAC	181688BSPP 181689BSPP	181688 181689
	9/16" - 18UNF	0.4 to 4	2.0 to 20.0	24 VDC 110 VAC	N/A N/A	165073 165074
Stainless Steel	1/2"	6 to 45	15.0 to 75.0	24 VDC 110VAC	165077BSPP 165078BSPP	165077 165078
	3/4"	---	20 to 112.5	24 VDC 110 VAC	181691BSPP 181692BSPP	181691 181692
	1"	---	30 to 225	24 VDC 110 VAC	181693BSPP 181694BSPP	181693 181694

\* With use of Low-Flow-Adapter supplied,

FLOW SWITCHES

Pressure Drop Typical

throughout all options

Standard Flow Range Units

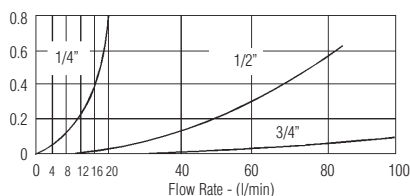

Low Flow Range Units

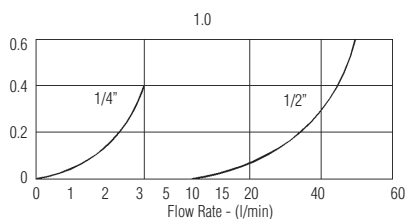

High Flow Units

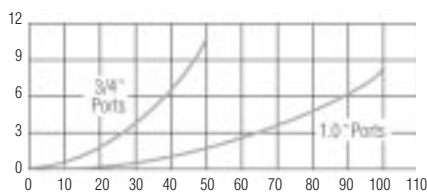

Installation and Maintenance

A proper installation will enhance RotorFlow sensor performance. Install using standard pipe fitting tools; horizontal fluid lines are recommended. For further installation and maintenance recommendations, refer to one of the following instruction bulletins: RFO Types - Part Number 157258; RFI Types - Part Number 157259; RFS Types - Part Number 157261. Since their function is to monitor dynamic fluid flow, naturally the rotor will react to turbulence, pulsation, entrained air, and other flow anomalies induced in the flow stream by other process hardware. For optimum performance, install RotorFlow units where nominal flow conditions exist with ports located at the top. Incoming flow may be placed to either port; a minimum of 20 cm of straight pipe on the inlet side is required. When operating in the low flow range, the supplied Low Flow Adapter must be installed in the incoming port.

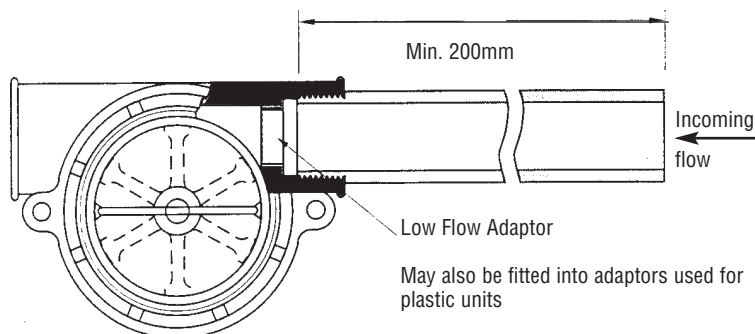

RotorFlow sensors connect to piping via NPT mating thread forms. The use of an appropriate thread sealant is necessary to assure a leak-tight connection. Permatex "No More Leaks" or 2 wraps of Teflon tape are the only sealants recommended for GEMS flow sensors. 150 micron filtration is recommended. However, should foreign particles enter RotorFlow sensor, accumulation is easily cleared by removing the lens from the body. The lens is removed by turning its centre rib 45° counter-clockwise, and then pulling it out. To reinstall the lens, simply reverse the process.

Dimensions (in mm)

RFA, RFO, RFS Polypropylene Bodies

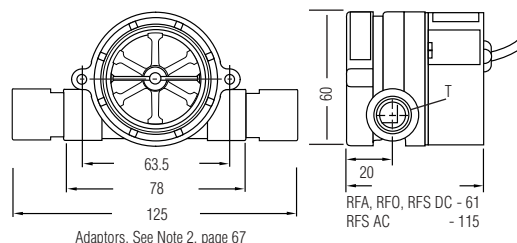

Metal Bodies

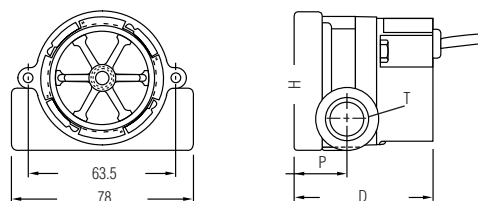

T	W	H	D DC models	D AC models	P
1/4	77	60	61	114	20
1/2	77	60	61	114	22
3/4	100	66	75	121	27
1	100	66	75	121	27

Panel Mounting

Any RotorFlow sensors may be panel mounted using holes integrated into the bodies.

Two (2) mounting ears are provided at the body centre line to receive 3.5mm ø self tapping screws (e.g. DIN 7971-B 3, 5 x 19) to accommodate panel mounting of the plastic RotorFlow units.

Note: ANSI T type 23 self-tapping screw are recommended. They may be replaced with standard machine screws if reinstallation should be required.

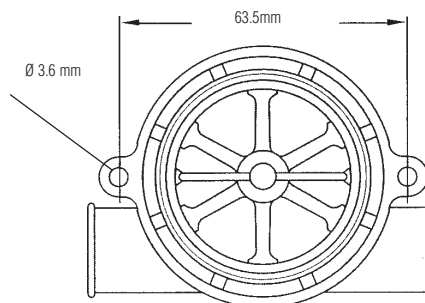

**Important:** In either case, pressure must be relieved from the system prior to sensor clean-out.

Low Flow Applications

A low flow adaptor is supplied with all Rotorflow units. It is used to produce accurate response at low flow rates. Install the adapter, as shown above, in the port selected for incoming flow.