



# Pressure Sensors



**Gems**<sup>™</sup>  
Sensors & Controls

# Welcome to Gems Sensors

## Pressure Catalogue

INTRODUCTION

This catalogue describes our best selling pressure sensors, from economical OEM to aerospace quality transducers we have the choice and variety of configurations for most applications. The catalogue is divided into sections, for each range of products, and includes special pages describing our immersible sensors. Dimensional drawings, specifications and photographs are included providing comprehensive technical information for designers and specifiers.

We want to make it as easy as possible for you to do business with Gems. This catalogue should provide you with all you need to know about a pressure transducer or transmitter and includes a section for accessories and additional information. Should you not find what you are looking for please do not hesitate to contact your nearest Gems Sales Office or Representative. A list of our Representatives can be found at the back of this catalogue.

We understand that some applications require a bespoke sensor. Our engineers are ready to offer comprehensive advice and, whether it is a special connector, a different label or a completely re-designed package, we can provide timely cost effective solutions.

Gems also manufactures pressure switches, level sensors, flow sensors, and tank sight level indicators some of which are illustrated on page 71. Many of these products are available ex stock through our express shipping services in Europe and North America. Please contact your sales office for full details.

For the last 40 years we have listened, and responded, to our customer needs, helping our OEM customers to maintain a competitive edge and, providing end users with reliable solutions to the most demanding pressure measuring problems.



Visit us at: [www.gems-sensors.co.uk](http://www.gems-sensors.co.uk) or [www.gemssensors.com](http://www.gemssensors.com)

### The fastest way to more information:

...just complete the form below and fax it to your nearest sales office (address on back page)

**From:**

Name .....	Company .....
Department.....	Street/PO Box .....
Post Code/City.....	Telephone .....
Email .....	Fax .....

I have the following application.....  
 .....  
 .....

and I would like to talk with one of your sales engineers. Please call me (date/time) .....

Please send me more information on:

- |  |   |
|--|---|
| <input type="checkbox"/> Gems Electro Optic Level Switches | <input type="checkbox"/> Gems Single Point Level Switches |
| <input type="checkbox"/> Gems Multi Point Level Switches   | <input type="checkbox"/> Gems Flow Indicators             |
| <input type="checkbox"/> Gems Flow Switches                | <input type="checkbox"/> Gems Pressure Switches           |

www.gemssensors.com

# 3100 Series Compact High Pressure OEM Pressure Transmitter

PRESSURE TRANSDUCERS

SPUTTERED THIN FILM

- ▶ 10 bar to 2200bar pressure ranges
- ▶ Less than 25mm long
- ▶ Choice of outputs

For OEMs that need consistent high levels of performance, reliability and stability the 3100 Series sputtered thin film units offer unbeatable price performance ratio in a small package size with all stainless steel wetted parts in the volumes required. A wide choice of electrical outputs as well as both electrical and pressure connections means the unit is suitable for most applications without modification. The compact construction of the 3100 series makes it ideal for installation where space is at a premium.

## Specifications

<b>Input</b>	
<b>Pressure Range</b>	0 to 10bar or 0 to 2200bar G (100 to 30,000psi)
<b>Proof Pressure</b>	2 x FS (Ranges 1600 & 2200bar 1.5x)
<b>Burst Pressure</b>	Ranges ~ 400bar 10 x minimum 600 & 1000b 4 x, 1600 & 2200 1.8x
<b>Fatigue Life</b>	Designed for more than 100,000,000 cycles
<b>Performance</b>	
<b>Long Term Drift</b>	0.1% FS/year non cumulative
<b>Accuracy</b>	±0.25% FS (Temp O/P ± 2.5%FS)
<b>Thermal Error</b>	±1% typical/100°C
<b>Compensated Temperature</b>	-40° to 120°C (-40° to 250°F)
<b>Operable</b>	-40° to 125°C (-40° to 250°F)
<b>Zero Tolerance</b>	±0.5% of span
<b>Span Tolerance</b>	±0.5% of span
<b>Mechanical Construction</b>	
<b>Pressure Port</b>	See ordering chart
<b>Wetted Parts</b>	17-4 PH Stainless Steel
<b>Electrical Connection</b>	See ordering chart
<b>Enclosure</b>	
	IP65 for electrical code B (with connector fitted) IP67 for electrical codes E, 6, 7, 8 and 9
<b>Vibration</b>	20G, 10-2000Hz sinusoidal
<b>Shock</b>	Withstands free fall to IEC 68-2-32 procedure 1
<b>Approvals</b>	CE
<b>Weight</b>	35 gms

## Individual Specifications

<b>Voltage Output Units</b>	
<b>Output</b>	See ordering chart (current 4.5mA)
<b>Supply Voltage</b>	2 Volts above Full Scale, to max 30 Volts
<b>Current Output Units</b>	
<b>Output</b>	4-20mA
<b>Supply Voltage</b>	10 to 30Vdc (24Vdc max for 110° and above)
<b>Max. Loop Resistance</b>	(Vs-10) x 50 ohms
<b>Ratiometric Output Units</b>	
<b>Output</b>	0.5 to 4.5Vdc (3.5mA max)
<b>Supply Voltage</b>	5Vdc, ± 10%

## MECHANICAL FITTINGS

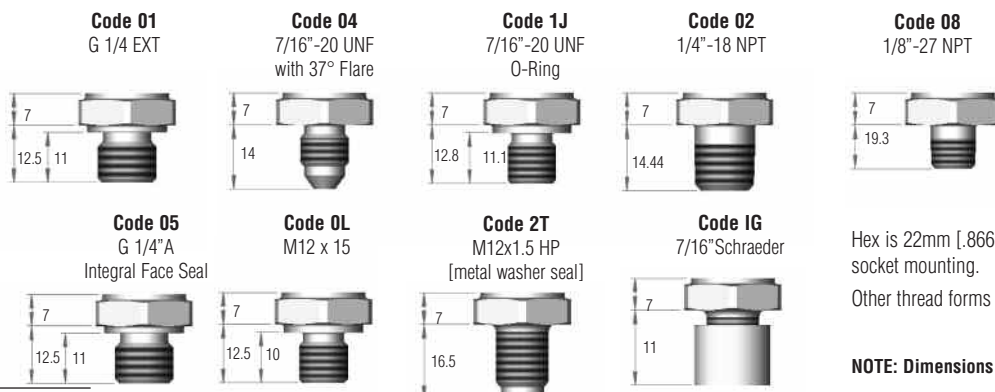

Hex is 22mm [.866] Across Flats (A/F) for deep socket mounting.  
Other thread forms available. Consult factory.

**NOTE: Dimensions in mm**

## Electrical Connectors



AMP Superseal 1.5



DIN 43650C Industrial



DIN 72585 Bayonet



M12 Ranges



Deutsch DTD4-4P



Packard Metri-pack

## How to Order

Use the **Bold** characters from the chart below to construct a product code

### Series

#### Variants to Standard Types

- 00** - Pressure output
- 01** - Pressure and temperature output (see **Note 1**)

#### Output

- B** - 4-20mA      **C** - 1-6V
- H** - 1-5V      **N** - 0.5 to 4.5V Non Ratiometric      **R** - 0-5 V
- S** - 0-10V      **T** - 0.5 to 4.5 Ratiometric

#### Pressure Range

- 0010G** - 10barG      **0100S** - 100barS      **1000S** - 1000barS )
- 0016G** - 16barG      **0160S** - 160barS      **1600S** - 1600barS ) (see **Note 2**)
- 0025G** - 25barG      **0250S** - 250barS      **2200S** - 2200 barS )
- 0040G** - 40barG      **0400S** - 400barS
- 0060G** - 60barG      **0600S** - 600barS

#### Integral Pressure Connection

- 01** - G1/4 External
- 02** - 1/4- 18 NPT External
- 04** - 7/16-20 UNF External
- 05** - G1/4 External Soft Seal
- 08** - 1/8 NPT External
- 0L** - M12 x 1.5 - 6g (600b and below)
- 1G** - Schraeder Deflator (Short)
- 1J** - 7/16 - 20 UNF External 'O' Ring Seal
- 2T** - M12 x 1.5-6g (1000b and above)

**310X**    **X**    **XXXXX**    **XX**    **X**    **000**

#### Electrical Connection

- 6** - AMP Superseal 1.5 Series
- 7** - DIN 72585 Bayonet
- 8** - Deutsch Series DT-04
- 9** - Packard Metripak
- B** - Industrial DIN
- E** - M12x 1

For mating electrical connectors and cables see page 67.

**Note 1** Pressure and temperature output available with voltage output and electrical connectors B, E, 7 and 8 only

**Note 2** Ranges 1000 bar and above available with 2T pressure port only.

### ELECTRICAL CONNECTOR

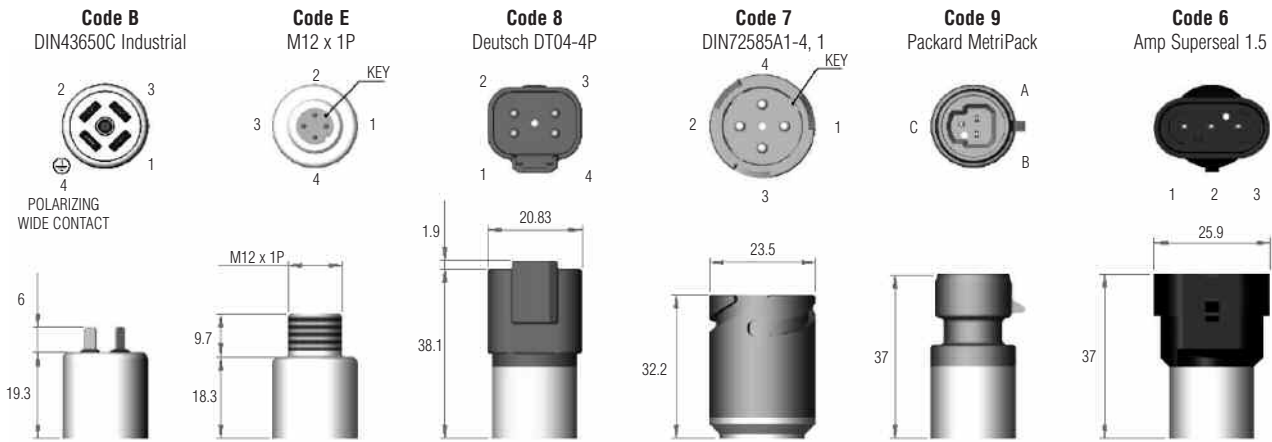

**Note:** The diameter of all cans is 19mm [.748]

Pin #	Function	
	Current	Voltage
1	N/A	Press O/P +VE
2	+VE	Supply +VE
3	N/A	Temp O/P +VE
4	-VE	Common

Pin #	Function	
	Current	Voltage
1	+VE	Supply +VE
2	N/A	Press O/P +VE
3	-VE	Common
4	N/A	Temp O/P +VE

Pin #	Function	
	Current	Voltage
1	-VE	Common
2	+VE	Supply +VE
3	N/A	Temp O/P +VE
4	N/A	Press O/P +VE

Pin #	Function	
	Current	Voltage
1	+VE	Supply +VE
2	-VE	Common
3	N/A	Press O/P +VE
4	N/A	Temp O/P +VE

Pin #	Function	
	Current	Voltage
A	-VE	Common
B	+VE	Supply +VE
C	N/A	Press O/P +VE

Pin #	Function	
	Current	Voltage
1	N/A	Press O/P +VE
2	-VE	Common
3	+VE	Supply +VE

# 3200 Heavy Duty Series OEM Pressure Transmitter

SPUTTERED THIN FILM  
PRESSURE TRANSDUCERS

- ▶ 10 bar to 600bar pressure ranges
- ▶ High proof pressure
- ▶ Choice of outputs

For OEMs that need stability and ruggedness the 3200 Series heavy duty pressure transmitters are designed with a thicker diaphragm and pressure snubber to withstand the rigours of cavitation or extreme pressure spikes which can be present in some applications such as hydraulic systems.

The 3200 has a modular construction which offers a wide selection of pressure ports and electrical connections in a small package size. All wetted parts are stainless steel ensuring excellent strength and fatigue life for long lasting operation.

## Electrical Connectors



AMP Superseal 1.5



DIN 43650C Industrial



DIN 72585 Bayonet



M12 Ranges



Deutsch DTD4-4P



Packard Metri-pack

## Specifications

### Input

<b>Pressure Range</b>	0 to 10bar to 600b (100 to 10,000psi)
<b>Proof Pressure</b>	4 x FS
<b>Burst Pressure</b>	Ranges ≤400bar 10 x minimum 600 4 x
<b>Fatigue Life</b>	Designed for more than 100,000,000 cycles

### Performance

<b>Long Term Drift</b>	0.1% FS/year non cumulative
<b>Accuracy</b>	±0.25% FS (Temp O/P ± 2.5%FS)
<b>Thermal Error</b>	±1% typical/100°C
<b>Compensated Temperature</b>	-40° to 120°C (-40° to 250°F)
<b>Operable</b>	-40° to 125°C (-40° to 250°F)
<b>Zero Tolerance</b>	±0.5% of span
<b>Span Tolerance</b>	±0.5% of span

### Mechanical Construction

<b>Pressure Port</b>	See ordering chart (current 4.5mA)
<b>Wetted Parts</b>	17-4 PH Stainless Steel
<b>Electrical Connection</b>	See ordering chart

**Enclosure** IP65 for electrical code B (with connector fitted)  
IP67 for electrical codes E, 6, 7, 8 and 9

<b>Vibration</b>	20G, 10-2000Hz sinusoidal
<b>Shock</b>	Withstands free fall to IEC 68-2-32 procedure 1
<b>Approvals</b>	CE
<b>Weight</b>	35 gms

## Individual Specifications

### Voltage Output Units

<b>Output</b>	See ordering chart (current 4.5mA)
<b>Supply Voltage</b>	2 Volts above Full Scale, to max 30 Volts

### Current Output Units

<b>Output</b>	4-20mA
<b>Supply Voltage</b>	10 to 30Vdc (24Vdc max for 110° and above)
<b>Max. Loop Resistance</b>	(Vs-10) x 50 ohms

### Ratiometric Output Units

<b>Output</b>	0.5 to 4.5Vdc
<b>Supply Voltage</b>	5Vdc, ± 10% (current 3.5mA)

## MECHANICAL FITTINGS

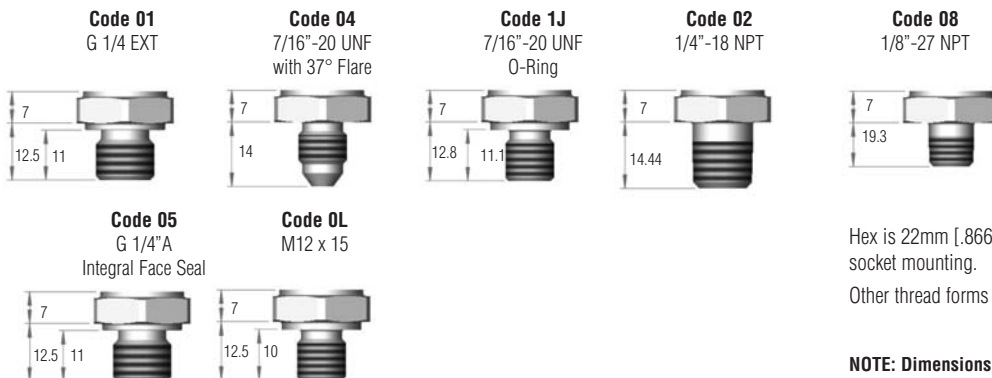

Hex is 22mm [.866] Across Flats (A/F) for deep socket mounting.  
Other thread forms available. Consult factory.

**NOTE: Dimensions in mm**

## How to Order

Use the **Bold** characters from the chart below to construct a product code

### Series

#### Variants to Standard Types

- 00** - Pressure output
- 01** - Pressure and temperature output (see **Note 1**)

#### Output

- B** - 4-20mA      **C** - 1-6V
- H** - 1-5V      **N** - 0.5 to 4.5V Non Ratiometric    **R** - 0-5V
- S** - 0-10V      **T** - 0.5 to 4.5 Ratiometric

#### Pressure Range

- 0010G** - 10barG    **0100S** - 100barS
- 0016G** - 16barG    **0160S** - 160barS
- 0025G** - 25barG    **0250S** - 250barS
- 0040G** - 40barG    **0400S** - 400barS
- 0060G** - 60barG    **0600S** - 600barS

#### Integral Pressure Connection

- 01** - G1/4 External
- 02** - 1/4- 18 NPT External
- 04** - 7/16-20 UNF External
- 05** - G1/4 External Soft Seal
- 08** - 1/8 NPT External
- 0L** - M12 x 1.5 - 6g (600b and below)
- 1J** - 7/16 - 20 UNF External 'O' Ring Seal

320X X XXXXX XX X X 00

#### Restrictor

- 0** - Not fitted
- R** - Fitted

#### Electrical Connection

- 6** - AMP Superseal 1.5 Series
- 7** - DIN 72585 Bayonet
- 8** - Deutsch Series DT-04
- 9** - Packard Metripak
- B** - Industrial DIN
- E** - M12x 1

For mating electrical connectors and cables see page 67.

**Note 1** Pressure and temperature output available with voltage output and electrical connectors B, E, 7 and 8 only

### ELECTRICAL CONNECTOR

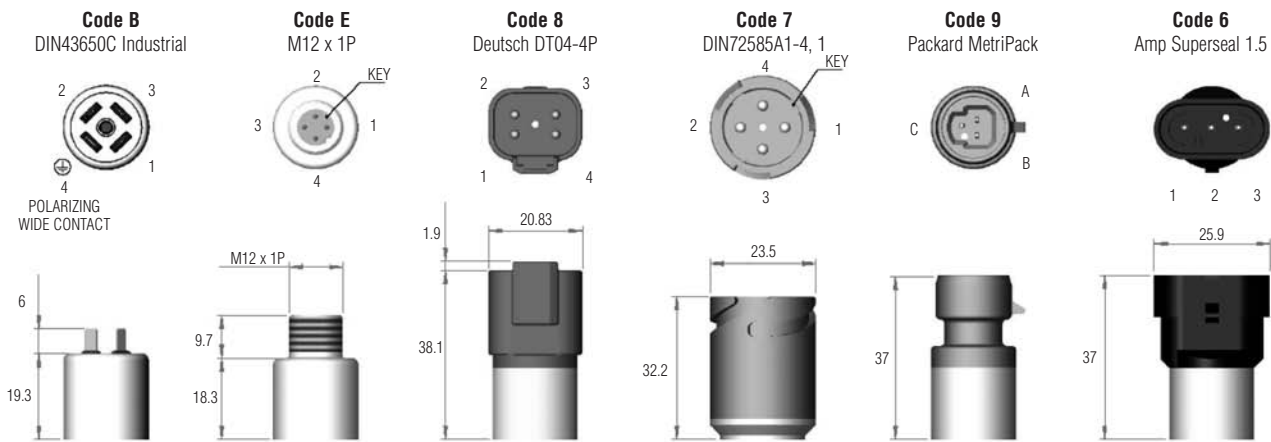

**Note:** The diameter of all cans is 19mm [.748]

Pin #	Function	
	Current	Voltage
1	N/A	Press O/P +VE
2	+VE	Supply +VE
3	N/A	Temp O/P +VE
4	-VE	Common

Pin #	Function	
	Current	Voltage
1	+VE	Supply +VE
2	N/A	Press O/P +VE
3	-VE	Common
4	N/A	Temp O/P +VE

Pin #	Function	
	Current	Voltage
1	-VE	Common
2	+VE	Supply +VE
3	N/A	Temp O/P +VE
4	N/A	Press O/P +VE

Pin #	Function	
	Current	Voltage
1	+VE	Supply +VE
2	-VE	Common
3	N/A	Press O/P +VE
4	N/A	Temp O/P +VE

Pin #	Function	
	Current	Voltage
A	-VE	Common
B	+VE	Supply +VE
C	N/A	Press O/P +VE

Pin #	Function	
	Current	Voltage
1	N/A	Press O/P +VE
2	-VE	Common
3	+VE	Supply +VE

# 4000 Series - High Performance, Long Term Stability Pressure Transducers

PRESSURE TRANSDUCERS

SPUTTERED THIN FILM

- ▶ Gauge, sealed, absolute, and differential pressure models
- ▶ Submersible, general purpose and weather proof enclosures
- ▶ High stability achieved by sputtered sensing element

The 4000 series provides exceptional levels of stability and other performance specifications in a wide variety of enclosures from submersible to differential styles. By using a sputtered sensing element, which achieves a molecular fusion of a strain gauge material, an insulating material, and the 17-4 PH ss sensing element, the 4000 series provides the most stable sensor construction possible. These sputtered sensors are packaged for harsh applications requiring long term service where precise laboratory type measurements are required.

Also in the 4000 series is a range of high performance amplified sensors with voltage and current outputs. These laboratory specification sensors utilise the same thin film sensor as 4000.

## Specifications

### Input

<b>Pressure Range</b>	0 to 1 - 0 to 690bar
<b>Proof Pressure</b>	2 x Full Scale (FS) (1.5 x FS for Inconel ports)
<b>Burst Pressure</b>	>35 x Fs <= 10bar (150psi) ranges >15 x FS <= 100bar (1500psi) ranges >8 FS <= 690bar (10,000psi) ranges
<b>Fatigue Life</b>	3 million FS cycles
<b>Common Line Pressure</b>	Max. 60bar absolute (850 psia) differential units only

### Performance

<b>Output*</b>	30mV +/- 1% (certificate supplied) (4010, 25 to 33mV)	
<b>Supply Voltage (Vs)</b>	10Vdc Regulated (15Vdc max)	
<b>Long Term Drift</b>	0.06% per year non cumulative	
<b>Performance Code</b>	Accuracy	Thermal error over any 50°C band between -54°C to +120°C

	Typical	Typical
<b>J</b>	0.1 % span	1.2 % span
<b>K</b>	0.1 % span	0.6 % span
<b>L</b>	0.08 % span	0.6 % span
<b>M</b>	0.08 % span	0.3 % span

<b>Compensated Temperatures</b>	-54° to 120 °C (-65° to 250°F)
<b>Operating Temperatures</b>	-54° to 135°C (-65° to 275°F) for twist lock conn. "C" -54° to 120°C (-65° to 250°F) for cable units "D" -20° to 50°C (-4° to 122°F) for submersible unit "M"
<b>Zero Tolerance</b>	0mV +/- 1mV for performance codes J & K 0mV +/- 0.6mV for performance codes L & M
<b>Bridge Resistance</b>	2200 to 5250 ohms

### Mechanical Configuration

<b>Pressure Port</b>	See ordering chart
<b>Wetted Parts</b>	17-4 PH ss (optional Inconel) [17-4 PH and 15-7 Mo Stainless Steel <= 1.6bar (30psi)] Differential: dry non corrosive gas only on reference port
<b>Electrical Connection</b>	See ordering chart
<b>Enclosure</b>	321 ss case IP40 for elec. Code "C" gauge datum IP65 for elec. Code "C" Absolute or Sealed Datum IP66 (weatherproof) for elec. code "D" IP68 (submersible) for elec. code "M"
<b>Vibration</b>	35g peak sinusoidal, 5 to 2000Hz
<b>Shock</b>	Withstands free fall to EIC 68-2-32 proc 1
<b>Approvals</b>	CE
<b>Weight</b>	150grams max (excluding cable)

Note: \* Inconel 2.5bar (30psi) range output is 25mV +/- 1%

Electrical connection	Voltage units	Voltage units				
		IN+	OUT+	OUT-	IN-	Case Earth
C "10-6 Bayonet"	A	B	C/F	D/E	Screen	
D Weatherproof cable	Red	Yellow	Blue	White	Screen	
M IP68 cable	Red	Yellow	Blue	White	Screen	

CE



## Dimensions (in mm)

Differential

Code C

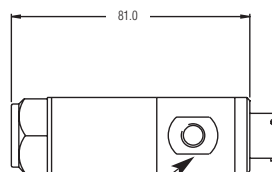

Absolute and Gauge

Code C

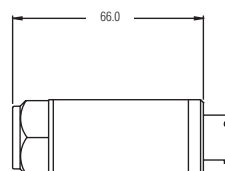

Absolute and Gauge

Code D

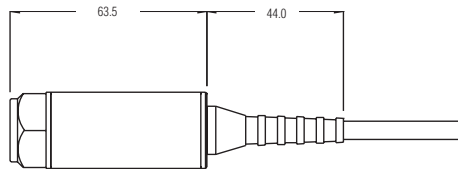

Absolute and Gauge

Code M

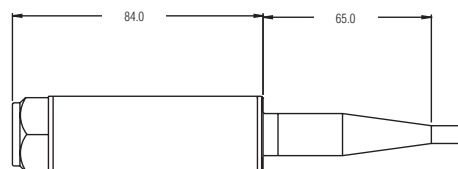

Maximum diameter 25.7mm

## How to Order

Use the **bold** characters from the chart below to construct a product code

**4000 K G B10 00 D 2 D J**

**Series** \_\_\_\_\_

4000 series for bar ranges, **4010** series for psi ranges

**Bridge Resistance** \_\_\_\_\_

**K** is 3500 ohms

**Pressure Datum** \_\_\_\_\_

**G** - Gauge; **A** - Absolute; **S** - Sealed; **U** - Uni-directional differential \*

**Insert pressure range code from table below** \_\_\_\_\_

**Pressure Port** see chart \_\_\_\_\_

**Electrical Connection** \_\_\_\_\_

**C** - Fixed plug size 10-6, mate sold separately part # 499532-0006  
**D** - Weatherproof Cable IP 66  
**M** - Immersible Cable IP68 to max depth 200 metres

**Approvals/Protection** \_\_\_\_\_

**2** - CE

**Cable Length in metres** (requires electrical connection to be cable codes D or M) \_\_\_\_\_

**U** - no cable **E** - 3 **G** - 10 **J** - 20 **L** - 30 **N** - 50 **Q** - 100 **S** - 150  
**D** - 1 **F** - 5 **H** - 15 **K** - 25 **M** - 40 **P** - 75 **R** - 125

**Static/Thermal Performance** \_\_\_\_\_

**J** - 0.1%/1.2%; **K** - 0.1%/0.6%; **L** - 0.08%/0.6%; **M** - 0.08%/0.3% typical over any 50°C band between -54°C to +120°C

\*Differential datum units are available in electrical code "C" only and performance codes either "L" or "M".

4000 Model Bar Ranges	Range Code	Gauge (G) Absolute (A) Sealed (S) Differential (U)
0 to 1	<b>A10</b>	<b>G, A, U</b>
0 to 1.6	<b>A16</b>	<b>G, A, U</b>
0 to 2.5	<b>A25</b>	<b>G, A, U</b>
0 to 4	<b>A40</b>	<b>G, A, U</b>
0 to 6	<b>A60</b>	<b>G, A, U</b>
0 to 10	<b>B10</b>	<b>G, A, U, S</b>
0 to 16	<b>B16</b>	<b>G, A, S</b>
0 to 25	<b>B25</b>	<b>G, A, S</b>
0 to 40	<b>B40</b>	<b>G, A, S</b>
0 to 60	<b>B60</b>	<b>G, A, S</b>
0 to 100	<b>C10</b>	<b>G, A, S</b>
0 to 160	<b>C16</b>	<b>G, A, S</b>
0 to 250	<b>C25</b>	<b>G, A, S</b>
0 to 400	<b>C40</b>	<b>G, A, S</b>
0 to 600	<b>C60</b>	<b>G, A, S</b>
0 to 690	<b>C69</b>	<b>G, A, S</b>

Diaphragm and internal port Inconel, external adaptors are available in stainless steel or Inconel

### Pressure Ports

Codes		Description
<b>SS</b>	<b>Inconel</b>	
<b>00</b>	<b>OK</b>	G 1/4 internal
<b>AO</b>	<b>AK</b>	G 1/4 AT external
<b>KO</b>	<b>KK</b>	7/16-20 UNF-3A external
<b>MO</b>	<b>MK</b>	M14 x 1.5 external
<b>PO</b>	<b>PK</b>	G1/2 AT external
<b>BO</b>	<b>BK</b>	1/4-18 NPT external
<b>GO</b>	<b>GK</b>	1/2-14 NPT external
<b>SO</b>	<b>SK</b>	7/16-20 UNJF-3A, MS 33656F4
<b>10</b>	<b>10</b>	Plastic nosecone
<b>20</b>	<b>20</b>	Plastic nosecone with restrictor
<b>30</b>	<b>30</b>	Sink weight nose cone

### Differential Units

<b>OD</b>	G1/4 internal ss, G1/8 internal ss
<b>OL</b>	G1/4 internal Inconel, G1/8 internal ss

# 4000 Series - High Temperature, High Performance, Long Term Stability Pressure Transducers

PRESSURE TRANSDUCERS

SPUTTERED THIN FILM

- ▶ Sealed and absolute models
- ▶ Suitable in temperatures up to 230°C (450°F)
- ▶ High stability achieved by sputtered sensing element

The high temp 4000 series provides exceptional levels of stability and other performance specifications while under excessive temperatures in harsh environments. Using a sputtered sensing element, which achieves a molecular fusion of a strain gauge material, an insulating material, and the 17-4 PH ss sensing element, generates the most stable sensor construction possible. These sputtered sensors are packaged for harsh applications requiring long term service where precise laboratory type measurements are required.



## Specifications

<b>Input</b>	
<b>Pressure Range</b>	0 to 1 - 0 to 690bar
<b>Proof Pressure</b>	2 x Full Scale (FS)
<b>Burst Pressure</b>	>35 x Fs <= 10bar ranges >15 x FS <= 100bar ranges >8 FS <= 690bar ranges
<b>Fatigue Life</b>	3 million FS cycles
<b>Performance</b>	
<b>Output</b>	25 to 38mV (certificate supplied)
<b>Supply Voltage (Vs)</b>	10Vdc Regulated (15Vdc max)
<b>Long Term Drift</b>	0.06% per year non-cumulative
<b>Accuracy</b>	0.1 % FS typical
<b>Thermal Zero Error</b>	.01 %FS/C (.005%/F) typical
<b>Thermal Span Error</b>	.01 %FS/C (.005%/F) typical
<b>Compensated Temperatures</b>	-54° to 200°C (-65° to 390°F)
<b>Operating Temperatures</b>	-54° to 230°C (-65° to 450°F) Conn. Code N -54° to 195°C (-65° to 385°F) Conn. Code C
<b>Zero Tolerance</b>	0mV +/- 10% FS
<b>Bridge Resistance</b>	590-1510 ohms
<b>Mechanical Configuration</b>	
<b>Pressure Port</b>	See ordering chart
<b>Wetted Parts</b>	17-4 PH ss [17-4 PH and 15-7 Mo Stainless Steel <= 1.6bar]
<b>Electrical Connection</b>	Code "N" 5 pins size 10 conn., Code "C" 6 pins size 10 conn.
<b>Enclosure</b>	321 ss, IP65
<b>Vibration</b>	35g peak sinusoidal, 5 to 2000 Hz
<b>Shock</b>	Withstands free fall to EIC 68-2-32 proc. 1
<b>Weight</b>	130grams max

## Dimensions (in mm)

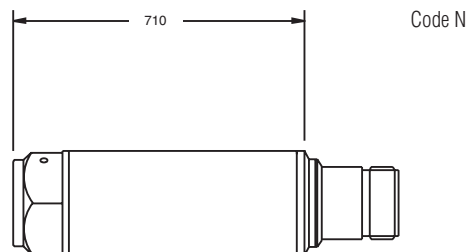

Maximum diameter 25.7mm

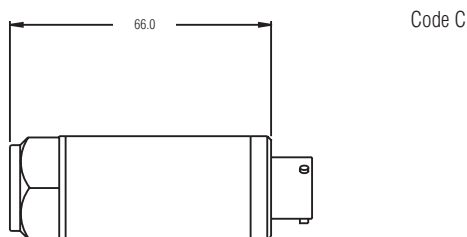

Electrical connection	Voltage units	Voltage units				Case Earth
		IN+	OUT+	OUT-	IN-	
C "10-6 Bayonet"	A	B	C	D	F	
N "10-5 Screw"	1	2	3	4	5	

## How to Order

Use the **bold** characters from the chart below to construct a product code

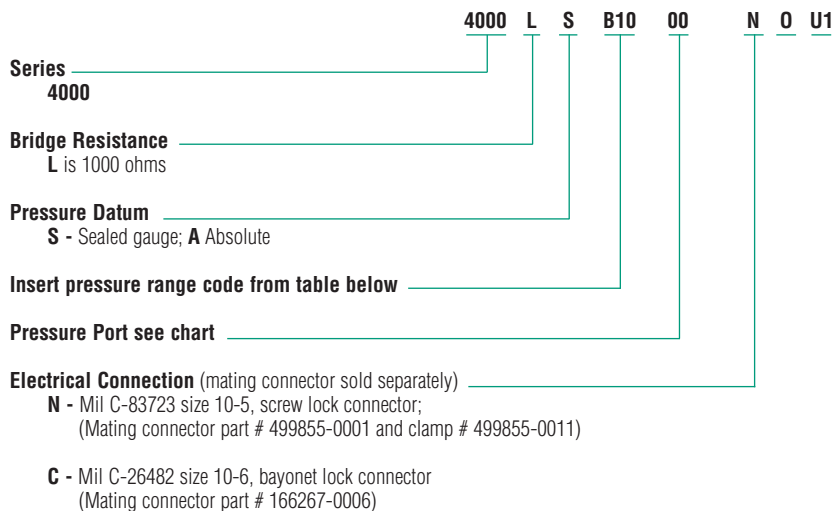

4000 Model Bar Ranges	Range Code	Absolute (A) Sealed (S)
0 to 1	<b>A10</b>	<b>A</b>
0 to 1.6	<b>A16</b>	<b>A</b>
0 to 2.5	<b>A25</b>	<b>A</b>
0 to 4	<b>A40</b>	<b>A</b>
0 to 6	<b>A60</b>	<b>A</b>
0 to 10	<b>B10</b>	<b>S, A</b>
0 to 16	<b>B16</b>	<b>S, A</b>
0 to 25	<b>B25</b>	<b>S, A</b>
0 to 40	<b>B40</b>	<b>S, A</b>
0 to 60	<b>B60</b>	<b>S, A</b>
0 to 100	<b>C10</b>	<b>S, A</b>
0 to 160	<b>C16</b>	<b>S, A</b>
0 to 250	<b>C25</b>	<b>S, A</b>
0 to 400	<b>C40</b>	<b>S, A</b>
0 to 600	<b>C60</b>	<b>S, A</b>
0 to 690	<b>C69</b>	<b>S, A</b>

Diaphragm and internal port Inconel, external adaptors are available in stainless steel or Inconel

### Pressure Ports

Code		
SS	Inconel	Description
<b>00</b>	<b>OK</b>	G 1/4 internal
<b>AO</b>	<b>AK</b>	G 1/4 AT external
<b>KO</b>	<b>KK</b>	7/16-20 UNF-3A external
<b>MO</b>	<b>MK</b>	M14 x 1.5 external
<b>PO</b>	<b>PK</b>	G 1/2 AT external
<b>BO</b>	<b>BK</b>	1/4-18 npt external
<b>GO</b>	<b>GK</b>	1/2-14 npt external
<b>SO</b>	<b>SK</b>	7/16-20 UNJF-3A, MS 33656E4

# 4700 Series - High Performance, High Stability, with 5:1 Turndown Capability Industrial Transmitters

SPUTTERED THIN FILM PRESSURE TRANSDUCERS

- ▶ Gauge, sealed and absolute models
- ▶ Submersible, general purpose and wash down enclosures
- ▶ IS models

The 4700 series provides precise laboratory type measurements in a rugged industrial package complete with turndown capabilities. Exceptional levels of stability and other performance specifications are achieved by using a sputtered sensing element, which achieves a molecular fusion of a strain gauge material, an insulating material, and the 17-4 PH ss sensing element. Sputtered thin film technology provides years of worry free measurements under demanding environmental conditions.

## Specifications

Input	
<b>Pressure Range</b>	1bar to 690bar; (10 to 10,000psi)
<b>Proof Pressure</b>	2 x Full Scale (FS) for Stainless Steel Units 1.5 x FS for Inconel Units
<b>Burst Pressure</b>	>35 x Fs <= 10bar ranges >15 x FS <= 100bar ranges >8 FS <= 690bar ranges
<b>Fatigue Life</b>	3 million FS cycles
Performance	
<b>Output</b>	4-20mA (2 wire)
<b>Supply Voltage (Vs)</b>	9.5 to 40Vdc
<b>Supply Voltage Sensitivity</b>	0.005% of max. span/Volt
<b>Long Term Drift</b>	0.1% of max span per year non-cumulative
<b>Accuracy</b>	0.1 % FS typical
<b>Thermal Error (typical)</b>	0.8% of max span for performance code E 0.5% of max span for performance code F
<b>Compensated Temperatures</b>	-25° to 75°C (-13° to 167°F)
<b>Operating Temperatures</b>	-25° to 85°C (-13° to 185°F) elec. conn. code C G & L -20° to 50°C (-4° to 122°F) elec. conn. code M, 3 -30° to 100°C (-22° to 212°F) process/media
<b>Zero Tolerance</b>	0.1%FS, typical
<b>Span Tolerance</b>	0.1%FS, typical
<b>Zero Adjustment</b>	+/- 10% (100% at factory) by potentiometer
<b>Span Adjustment</b>	17% to 130 % of span by potentiometer
<b>Max. Loop Resistance</b>	(Vs-9.5) x 50 ohms
Mechanical Configuration	
<b>Pressure Port</b>	See ordering chart
<b>Wetted Parts</b>	17-4 PH ss (optional Inconel) [17-4 PH and 15-7 Mo Stainless Steel <= 1.6 bar (30 Psi)]
<b>Electrical Connection</b>	See ordering chart
<b>Enclosure</b>	321 ss, 17-4 PH ss IP40 for gauge datum & electrical conn. code C, L IP65 for absolute and sealed datum codes C, L IP65 for electrical connection code G (with connector code fitted), 3 IP68 for electrical connection code M
<b>Vibration</b>	35g peak sinusoidal, 5 to 2000Hz
<b>Acceleration</b>	100g steady acceleration in any direction 0.05% FS/g for 1bar (15psi) range decreasing logarithmically to 0.0001%FS/g for 690bar (10000psi) range.
<b>Shock</b>	Withstands free fall to IEC 68-2-32 procedure 1
<b>Approvals</b>	CE ExI 1G, E Exia II CT4 (-40°C < T amb < 75°C) Cert BASEEFA 02ATEX0040X Lloyds Register
<b>Weight</b>	Approx. 305g (additional; cable 75grams/m)



Lloyds Register

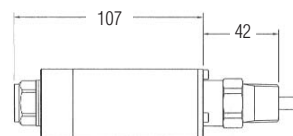

Code 3

1/2 - 14 NPT conduit

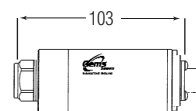

Code C

6 pin fixed plug size (10-6)

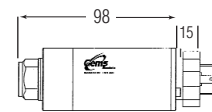

Code G

Fixed plug to DIN 43650 mate supplied

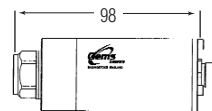

Code L

5 pin M12 x 1 fixed plug

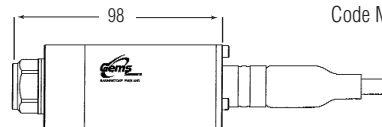

Code M

Immersible IP68 to 200mWG

Diameter 39mm

## How to Order

Use the **bold** characters from the chart below to construct a product code

Series **4700** - series for bar ranges

Output Response **B** - 4-20mA

Pressure Datum **G** Gauge; **S** Sealed; **A** Absolute  
(For compound ranges consult sales)

Insert pressure range code from table below

Pressure Port see chart

Electrical Connection **C** - Fixed plug size 10-6, 3-20mm conduit  
**M** - Submersible cable, to 200 metres  
**G** - Fixed plug to DIN 43650 mating plug supplied  
**L** - M12 x 1 (5 pin)  
**3** - 1/2 - NPT conduit

Approvals/Protection (For flame proof units see next page)  
**3** - CE  
**G** - ATEX approved ExII 1G, EEx ia IIC T4 (-40< Ta <+75°C), galvanic isolators

Cable Length in metres (requires electrical connection code M or 3)  
001 - 1 metre cable  
999 - 999 metre cable

Static/Thermal Performance **E** - 0.1%/0.8%; **F** - 0.1%/0.5%. 500mbar range performance code **E** only

4700 Model Bar Ranges	Range Code	Gauge (G)* Absolute (A) Sealed (S)
0 to 500mb	<b>N50</b>	<b>G, A</b>
0 to 1	<b>A10</b>	<b>G, A</b>
0 to 1.6	<b>A16</b>	<b>G, A</b>
0 to 2.5	<b>A25</b>	<b>G, A</b>
0 to 4	<b>A40</b>	<b>G, A</b>
0 to 6	<b>A60</b>	<b>G, A</b>
0 to 10	<b>B10</b>	<b>G, A, S</b>
0 to 16	<b>B16</b>	<b>G, A, S</b>
0 to 25	<b>B25</b>	<b>G, A, S</b>
0 to 40	<b>B40</b>	<b>G, A, S</b>
0 to 60	<b>B60</b>	<b>G, A, S</b>
0 to 100	<b>C10</b>	<b>G, A, S</b>
0 to 160	<b>C16</b>	<b>G, A, S</b>
0 to 250	<b>C25</b>	<b>G, A, S</b>
0 to 400	<b>C40</b>	<b>G, A, S</b>
0 to 600	<b>C60</b>	<b>G, A, S**</b>
0 to 690	<b>C69</b>	<b>G, A, S**</b>

\* For compound ranges consult sales

\*\* Internal Inconel fitting required external fitting can be SS.

### Pressure Ports

Codes		Description
SS	Inconel	
<b>00</b>	<b>OK</b>	G 1/4 internal
<b>AO</b>	<b>AK</b>	G 1/4 AT external
<b>KO</b>	<b>KK</b>	7/16-20 UNF 3A external
<b>MO</b>	<b>MK</b>	M14 x 1.5 external
<b>PO</b>	<b>PK</b>	G1/2 AT external
<b>BO</b>	<b>BK</b>	1/4-18 NPT external
<b>GO</b>	<b>GK</b>	1/2-14 NPT external
<b>SO</b>	<b>SK</b>	7/16-20 UNJF external, MS 33656E4
Immersible		
<b>19</b>		Plastic nose cone
<b>20</b>		Nose cone with restrictor
<b>30</b>		Nose cone w/ss Sink Weight

Electrical connection	Wiring			
	(+)	(-)	EARTH	
<b>G</b>	"DIN"	1	2	4
<b>C</b>	"10-6 Bayonet"	A	B	E
<b>M</b>	IP 68 cable	R	BL	DRAIN
<b>E</b>	M12 x 1	1	2	4
<b>3</b>	Conduit	R	BL	DRAIN

R = Red BL = Blue

# 9000 Series CANbus Digital Output Pressure Transducer

PRESSURE TRANSDUCERS

HIGHLY ACCURATE

- ▶ High accuracy over wide operating temperature range  
T.E.B.  $\pm 0.2\%$  Span,  $-40^{\circ}\text{C}$  to  $+85^{\circ}\text{C}$
- ▶ Excellent long term stability  $<0.05\%$  per year, non-cumulative
- ▶ Small size: 25mm diameter, 120mm length
- ▶ Isolated high speed CAN interface - ISO11898
- ▶ Programmable update rate
- ▶ Standard application interface - CANopen DS301 & DSP404
- ▶ In system programmable
- ▶ Self diagnostics - bridge fault detection, hours in service, watchdog, last calibration date, next calibration date
- ▶ Unsurpassed customer support - Rapid Development Kit

The 9000 CANBUS pressure transducer meets the demands of the test and measurement industry, including automotive and marine applications, with high levels of accuracy over a wide temperature range. The digital output in engineering units eliminates the need for user system calibration.

Designed to have a wide input voltage range, input to output isolation, immunity to noise and self-diagnostics the 9000 is ideal for electrically noisy environments or applications where earthing or grounding can be a problem.

Through the standard CANopen protocol multiple devices can be used on a single bus reducing user cabling.

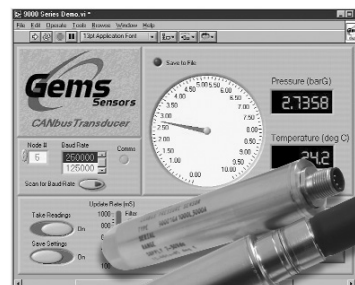

### Dimensions (in mm)

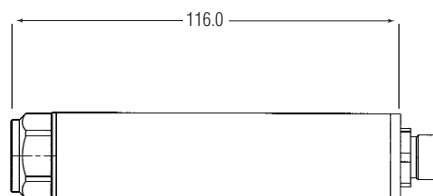

### Specifications

<b>Input</b>	
<b>Pressure Range</b>	0 to 1 - 0 to 690bar Gauge or Absolute
<b>Proof Pressure</b>	2 x FS (ranges $<400\text{b}$ ) 1.5 x FS ( $\geq 400\text{b}$ )
<b>Burst Pressure</b>	$>35$ x FS for ranges $\leq 6\text{bar}$ $>15$ x FS for ranges $\geq 100\text{bar}$ $>4$ x FS for ranges $\leq 690\text{bar}$
<b>Supply Voltage</b>	7-30Vdc, 0.6W
<b>Performance</b>	
<b>Long Term Stability</b>	Zero drift $<0.05\%$ Full range out put non cumulative
<b>Accuracy</b>	$\pm 0.1\%$ Full Scale
<b>Total Error Band</b>	$\pm 0.2\%$ Full Scale
<b>Compensated Temperature</b>	$-40^{\circ}$ to $85^{\circ}\text{C}$
<b>Operating Temperature</b>	$-40^{\circ}$ to $85^{\circ}\text{C}$
<b>Mechanical Configuration</b>	
<b>Pressure Port</b>	(see table below)
<b>Wetted Parts</b>	17-4 PH or Inconel
<b>Electrical Connection</b>	5 pin M12 x 1, cable to IP68, others on request
<b>Enclosure</b>	SS
<b>Vibration</b>	$<0.08\%$ FRO/g 20Hz to 2000Hz, 35g
<b>Shock</b>	Withstands free fall to IEC 68-2-32 procedure 1
<b>Approvals</b>	CE Emissions EN 61000-6-4, Immunity EN 61000-6-2
<b>Weight</b>	$<180\text{grams}$

### Connection Code

L	M12	(+)	(-)	Shield	CAN Hi	CAN Lo	
		2	3	1	4	5	

## How to Order

Use the **bold** characters from the chart below to construct a product code

Series **9000** 1 G B10 OK L 3 000 A

Output 1 - Canbus

Datum G - Gauge  
A - Absolute  
S - Sealed Gauge

Pressure Ranges - bar

<b>A10</b>	1	<b>B10</b>	10	<b>C10</b>	100
<b>A16</b>	1.6	<b>B16</b>	16	<b>C16</b>	160
<b>A25</b>	2.5	<b>B25</b>	25	<b>C25</b>	250
<b>A40</b>	4	<b>B40</b>	40	<b>C40</b>	400
<b>A60</b>	6	<b>B60</b>	60	<b>C60</b>	600
				<b>C69</b>	690

Pressure Adaptor

Stainless Steel	Inconel	Description
<b>00</b>	<b>OK</b>	G1/4 Internal
<b>AO</b>	<b>AK</b>	G1/4 AT External
<b>KO</b>	<b>KK</b>	7/16-20 UNF-3A External
<b>MO</b>	<b>MK</b>	M14 x 1.5 External
<b>PO</b>	<b>PK</b>	G1/2 AT External
<b>BO</b>	<b>BK</b>	1/4-18 NPT External
<b>GO</b>	<b>GK</b>	1/2-14 NPT External
<b>SO</b>	<b>SK</b>	7/16-20 UNJF-3A, MS 33656F4

Performance Code  
Static/Thermal  
0.05/0.2

CE Marked

Electrical Connection  
L - M12 Industrial 5 pin

## Accessories

Order Code	Description
557002	Restrictor Kit
499877-1000	Saddle Mounting Kit
562320-02M0	2m, unscreened, 5 core, cable - Terminated to M12 male connector
562320-05M0	5m, unscreened, 5 core, cable - Terminated to M12 male connector
562321	Rapid Development Kit - including 9V battery, M12 to 9 way D type cable terminated assembly, USB to CAN Interface, Gems start up CD ROM
562293	User manual
557749	M12, 5 pole duo field wireable connector with screw terminals

### Isolating Needle Valve

Part No. 557740

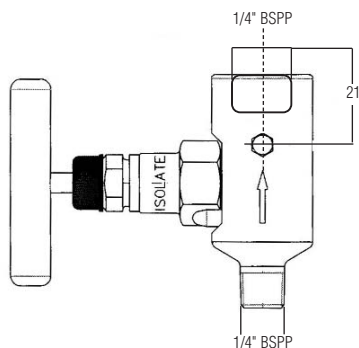

### Cable and Cable Assemblies

Part No.	Sheath	Operating Temperature
557692	Polyurethane	-20 to +50°C
557725	Hytrel	-40 to +100°C
496687	Polylofin	-54 to 120°C

### Temperature Isolator 558564 - 0001

Pigtail, siphon tubes and other forms of temperature isolation are used to reduce media temperature at the transducer. This self-contained 316 SS temperature isolator is packaged in a small housing 92mm long, and reduces the media temperature at the transducer, to about a fifth (transducer temp = media temp/5 + ambient temp). Max. temp. 400°C, max. pressure 400bar.

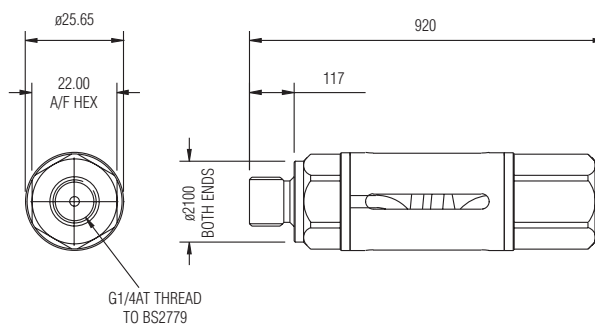

### Cable Assemblies: 3100/3200 Series pages 22 and 24

557703 - 01M0	12mm x 1 4pin electrical connector with 1metre cable
557703 - 02M0	12mm x 1 4pin electrical connector with 2metre cable
557703 - 03M0	12mm x 1 4pin electrical connector with 3metre cable
557703 - 04M0	12mm x 1 4pin electrical connector with 4metre cable
557703 - 05M0	12mm x 1 4pin electrical connector with 5metre cable

## Accessories

### Mounting Clamps

Generally our pressure transducers are supported by the piping they are mounted to, however when thin tubing, vibrations or large transducers are present then a mounting clamp is required. These clamps utilise a plastic-mounting bracket to

secure the transducer's outer case and a metal base strip to firmly attach the clamp to a surface.

Polypropylene -30 to 90°C	Polyamide -40 to 120°C	For Pressure Transducers	C	
499877-1000	499877-1001	4000 series (25 mm dia.)	64	
499877-1120	499877-1121	1200, 1600, 2200, 2600, 2800 series (28 mm dia.)	73	
499877-1500	499877-1501	4700, 5000 & 6700 series (38 mm dia.)	86	

### Cylindrical Connectors

Part Number	Size	Temperature	For Use With	
166267-0006	10-6 Bayonet	-70 to 195°C	4000-C	
499532-0006	10-6 Bayonet	-54 to 120°C	4000-C 5000-C 1600-C 2600-C 2800-C 4700-C 6700-C	
499855-0001 Requires strain relief clamp 499855-0011	10-5 twist	-54 to 230°C	4000-N	
557702	DIN 72585	-40 to 140°C	3000-7	Drawing not available
557703-0000	12mm x 1 4pin	-20 to 120°C	3000-E	Drawing not available
557704-0000	12mm x 1 5pin	-20 to 120°C	4700-L, 5000-L 6700-L, 9000-L	Drawing not available

### Square/Rectangular Connectors

Part Number	Type	Temperature	For Use With	
557254	DIN 43650A	-20 to 120°C	1600-G, 2600-G, 4700-G 5000-G, 6700-G, 1700-G, 1701-G	
557230	Industrial DIN connector	-20 to 120°C	1200-A, 2200-A	
557701	Amp Superseal	-40 to 125°C	3000-6	Drawing not available

## Restrictors

In most applications quasi static pressure measurement is all that is required. Often, transient pressure pulses are present in the system and it is recommended that a rapid acting pressure snubber or a restrictor is fitted to protect the transmitter or transducer. These pulses are often classified as water or pipe hammer.

Pressure snubbers are widely available and generally employ a moving element to isolate the sensor from a pressure pulse. A high volume displacement is

usually necessary for satisfactory operation.

Since our pressure sensors require only a low volume displacement to actuate, these snubbers may not provide adequate protection. Our restrictors on the other hand attenuate high frequency pulses and only allow steady state or slow changes to pass through. These thread directly into 4000, 4700 and 6700 series, and also 22/2600 and 2800 with G1/4 threads. Available in stainless steel these are designed for hydraulic applications.

Description	Part Number	
Integral capillary 0.5mm diameter, 13.5mm long plus a bleed screw all in stainless steel	466175-0000	
This restrictor has a helical groove, approximately 0.5mm diameter and 56 mm long. Made in japanned steel.	557002	
As above but in stainless steel	557000-0002	

## Industrial Bonded Seals

Description	Part Number	
Sealing for G1/4 thread. Nitrile in zinc plated steel, temperature range -40 to 100°C.	232646-0002	
Sealing for G1/4 thread. Viton in cadmium plated steel, temperature range -26 to 200°C.	499207-0002	
Sealing for G 1/8 thread. Nitrile in zinc plated steel, temperature range -40 to 100°C.	232646-0006	

# Ingress Protection (IP) Codes

FIRST NUMERAL Protection against solid bodies		SECOND NUMERAL Protection against liquid	
		0	1
Example: IP65 - equipment is dust-tight and protected against water jets		0	NO PROTECTION
		1	VERTICALLY DRIPPING WATER
0	NO PROTECTION	2	ANGLED DRIPPING WATER -75 TO 90°
1	OBJECTS GREATER THAN 50mm	3	SPRAYED WATER
2	OBJECTS GREATER THAN 12mm	4	SPLASHED WATER
3	OBJECTS GREATER THAN 2.5mm	5	WATER JETS
4	OBJECTS GREATER THAN 1.0mm	6	HEAVY SEAS (HOSE PROOF)
5	DUST-PROTECTED	7	EFFECTS OF IMMERSION TO 1 METER
6	DUST-TIGHT	8	INDEFINITE IMMERSION TO SPECIFIED DEPTH
6K	DUST TIGHT	9K	JET WASH PROOF

### ELECTROMAGNETIC CAPABILITY

Meets the requirements for CE marketing of EN50081-2 for emissions and EN50082-2 for susceptibility.

TEST DATA:

- ▶ EN6100-4-2 Electrostatic Discharge. 8kV air discharge. 4kV contact discharge. Unit survived.
- ▶ ENV50140 Radiated RF Susceptibility. 10V/m, 80MHz-1GHz, 1kHz mod. Maximum recorded output error was <math>\leq \pm 1\%</math>.
- ▶ ENV50204 Radiated RF Susceptibility to Mobile Telephones. 10V/m, 900MHz Maximum recorded output error was <math>\leq \pm 1\%</math>.
- ▶ EN61000-4-4 Fast Burst Transient. 2kV. 5/50ns, 5kHz for 1 minute. Unit survived.
- ▶ ENV50141 Conducted RF Susceptibility. 10Vms. 1kHz mod. 150kHz - 80MHz. Maximum recorded output error was <math>\leq \pm 1\%</math>.

**CE MARKING**  
The CE mark shows that a product complies with the requirements of all European Community Directives relevant to that product.

Also available from Gems

### Electro Optic Level sensors

ELS-1100 ELS-1200

- ▶ Compact size
- ▶ Integral electronics
- ▶ No moving parts
- ▶ Simple installation



These level sensors use an infrared LED and receiver. When media is in contact with the prism the light is reflected onto the receiver. Manufactured in Polysulphone, the ELS is available in a variety of mountings, power requirements and electrical terminations.

### Single Point Level Switches

#### Vertical Mounting

- ▶ Simple working principle
- ▶ Precise repeatability
- ▶ Cost effective



Gems has a large choice of single float level switches with designs for horizontal or vertical mounting. The wide variety of materials available mean compatibility with most media.

#### Horizontal Mounting

- ▶ Robust design
- ▶ High vibration and shock resistance
- ▶ Customer defined solutions available

Available with flanged or threaded mountings, the Gems multi level switches use the same durable technology as single point switches. With up to 7 switch points per unit and a choice of plastics, brass and stainless steel construction it is possible to configure a solution to almost any application.

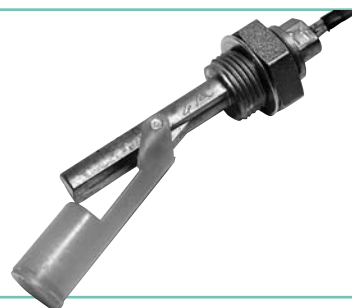

### Multiple Point Level Switches

- ▶ Bright visual indication
- ▶ Pulse, switch or voltage output options

Today's Rotorflow sensors combine the visual indication of flow with electronic outputs.



### Flow Switches and Indicators

- ▶ Rugged, low maintenance design
- ▶ Flow rates from 0.005 to 380l/min

Flow switches are available in paddle, piston and shuttle types with a large choice of connections. Typical applications include machine tool flow monitoring, air conditioning, plastic moulding and laser cooling.



### Pressure Switches

- ▶ Field-Adjustable or Factory Set Switches
- ▶ High Proof Pressure
- ▶ Rugged and Dependable

Gems offers a choice of pressure switches, from compact cylindrical models for OEM use, to larger, enclosed units for rugged process applications.



## For Your Fast Response Sales Office

<b>GB</b>	Sales Hotline: + 44 1256 320244 Fax Hotline: + 44 1256 473680	<b>D</b>	Sales Hotline: + 49 60 47 9611-0 Fax Hotline: + 49 60 47 9611-11
<b>I</b>	Sales Hotline: +39 02 9330 0154 Fax Hotline: +39 02 9330 0150	<b>F</b>	Sales Hotline: + 33 1 48 19 99 70 Fax Hotline: + 33 1 48 19 99 79
<b>A</b> <b>HR</b> <b>SLO</b>	<b>Lico Industrievertretungen GmbH</b>		Sales Hotline: + 43 1 706 4300 Fax Hotline: + 43 1 706 4131
<b>B</b>	<b>Doedijns PMC NV</b>		Sales Hotline: + 32 3 570 9383 Fax Hotline: + 32 3 575 1230
<b>S</b>	<b>Beving Elektronik</b>		Sales Hotline: + 46 8 680 1169 Fax Hotline: + 46 8 680 1188
<b>DK</b>	<b>Eltech Components AS</b>		Sales Hotline: + 45 7010 1410 Fax Hotline: + 45 4320 0777
<b>FIN</b>	<b>Stig Wahlstrom OY</b>		Sales Hotline: + 358 9 502 4400 Fax Hotline: + 358 9 452 2735
<b>GR</b>	<b>Tesima SA</b>		Sales Hotline: + 30 210 492 2238 Fax Hotline: + 30 210 492 2245
<b>NL</b>	<b>Doedijns PMC BV</b>		Sales Hotline: + 31 182 30 2888 Fax Hotline: + 31 182 30 2777
<b>H</b>	<b>Lico Hungaria GmbH</b>		Sales Hotline: + 43 1 706 43 00 Fax Hotline: + 43 1 706 41 31
<b>IL</b>	<b>United Instruments Ltd</b>		Sales Hotline: + 972 3 688 3244 Fax Hotline: + 972 3 537 6157
<b>N</b>	<b>Hypotech</b>		Sales Hotline: + 47 32 80 7400 Fax Hotline: + 47 32 80 7401
<b>NI</b>	<b>Parks Automation</b>		Sales Hotline: +28 9077 7743 Fax Hotline: +28 9077 7794
<b>P</b>	<b>Contimetra Instrumentos</b>		Sales Hotline: + 351 214 203 900 Fax Hotline: + 351 214 203 901
<b>E</b>	<b>Sistec S L</b>		Sales Hotline: + 34 93 573 0950 Fax Hotline: + 34 93 573 0995
<b>CH</b>	<b>Bachofen AG</b>		Sales Hotline: + 41 1 944 1111 Fax Hotline: + 41 1 944 1233
<b>TR</b>	<b>Elimko Electronics Imalet Ve</b>		Sales Hotline: + 90 312 212 6450 Fax Hotline: + 90 312 212 4143
<b>RSA</b>	<b>Transducer Technology</b>		Sales Hotline: + 27 11 397 7733 Fax Hotline: + 27 11 425 2294
<b>CZ</b> <b>EST</b> <b>LV</b> <b>LT</b>	<b>Amtest</b>		Sales Hotline: + 420 572 572 358 Fax Hotline: + 420 572 572 358

**REPRESENTATIVE LIST**

**www.gemssensors.com**

*If your country is not listed above, please contact one of the Gems' sales offices on the back cover*

Represented by



**United Kingdom**

Gems Sensors  
Lennox Rd  
Basingstoke  
Hants. RG22 4AW  
Tel: +44 (0)1256 320244  
Fax: +44 (0)1256 473680  
Email: sales@gems-sensors.co.uk

**France**

Gems Sensors  
Z.I. des Mardelles  
94 - 106, rue Blaise Pascal  
93602 Aulnay-sous-Bois Cédex  
Tel: +33 (0)1.48.19.99.70  
Fax: +33 (0)1.48.19.99.79  
Email: sales@gems-sensors.fr

**Germany\***

Gems Sensors  
Vogelsbergstr. 47  
D 63674 Albstadt  
Tel: + 49 6047-9611-0  
Fax: + 49 6047-9611-11  
Email: sales@gems-sensors.de

**Italy\***

Gems Sensors  
Via Leonardo da Vinci, 45/47  
20020 Lainate (MI)  
Tel: +39 02 933 00 154  
Fax: +39 02 933 00 150  
Email: sales@gems-sensors.it

**North America**

Gems Sensors  
One Cowles Road  
Plainville  
CT 06062-1198  
Tel: +1 860 747 3000  
Fax: +1 860 747 4244  
Email: info@gemssensors.com

\* Gems Sensors - Germany and Italy are agents acting on behalf of Gems Sensors a division of Danaher UK Industries Ltd, Registered No. 2815444 England

Due to a policy of continuous development we reserve the right to amend specifications without prior notice.

*Gems Sensors is a Member of the Danaher Corporation*

Produced by Clere Design & Print. [www.clere.uk.com](http://www.clere.uk.com)



Visit our website at [www.gemssensors.com](http://www.gemssensors.com)