



## HOT-TAPPED INSERTION MAGNETIC PROBE

Series MFX Insertion MagProbe™ Flow Meters feature advanced DC-Pulsed magnetic flow measurement technology. The Series MFX is a cost-effective solution for accurate measurement of conductive liquid in closed conduit, pressurized-pipes without process shutdown. The "flat tip" design will reduce fouling in applications where suspended solids are present.

The MFX reliably measures most conductive fluids including water, raw sewage, wastewater, clarified water, RAS, WAS, primary sludge and cooling tower water, as long as adequate lengths of straight pipe are available where the sensor is installed.

The MFX system consists of a hot-tappable insertion-type sensor that mounts through a 1-1/2" ball valve pipe-tap into the flowing liquid, and a remote digital display enclosure. The digital display is utilized to

program engineering units, view flow rate/totalizer values and provide process outputs. Velocity and pipe diameter information are entered by the user via the display keypad or *ULTRALINK™* software and used to calculate volumetric flow, over wide flow ranges, with a high degree of accuracy.

The Series MFX is more versatile and convenient than most conventional full-pipe magnetic meters. MFX meters can be universally applied to a large range of pipe sizes without hardware changes, compared to the specific internal pipe dimension design of conventional magnetic meters. In addition, cost differences are minimal when moving to larger pipe sizes.

MagProbe sensors are available in various lengths to accommodate limited access mounting configurations and installation in pipe internal diameters 4 to 120 inches (102 to 3048 mm).

### FEATURES

- Absolute (bi-directional) measurements from 0.1 to 30 FPS (0.03 to 9 MPS).
- Integrated sensor pre-amplifier permits separation of up to 990 feet (297 m) between the sensor probe and MFX electronic analyzer.
- Optional, optically isolated, field replaceable input/output modules include: 4-20mA, dual-relay, rate pulse, RS232 and RS485.
- Hot-tap sensor can be installed and retracted from process piping without draining or depressurizing the system.
- High impedance input circuits minimize the influence of electrode coating.
- Industrial-grade sensor design: NEMA 6 (IP67) submersible, temperature to +225 °F (+105 °C), pressure to 700 PSIG (48 bar), titanium, 316SS, Viton® and PVDF wetted materials.
- *ULTRALINK* PC utility permits configuration and intelligent diagnostics to be performed.



**DYNASONICS**  
DIVISION OF RACINE FEDERATED INC.

## PRINCIPLES OF OPERATION

The MagProbe™ is a point-velocity measuring device used for measuring electrically conductive liquids, such as water and water-based fluids, in closed piping systems. The unit operates utilizing Faraday's principle of magnetic conduction, whereby a moving conductor (the liquid) has a voltage imposed on it that is directly proportional to two variables – the strength of a local magnetic field and the velocity of the moving conductor.

### Imposed voltage $\propto$ Magnetic field $\times$ Fluid velocity

If the strength of the magnetic field is held constant, then the magnitude of the voltage will be proportional to the velocity of the moving conductor. The equation then simplifies to **Imposed voltage  $\propto$  Fluid velocity**. The MFX applies tri-stated, alternating polarity DC pulses to an integral electromagnet (See Figures 1 & 2). Voltage measurements are made with the magnet off, to measure ambient background noise, and then with the magnet on in both polarities. The magnitude difference in voltage measured is proportional to flow. Once fluid velocity is measured, then various volumetric flow measurements will be obtained if the pipe internal diameter (I.D.) is known.

Point-velocity flow meters measure the fluid velocity at a specified depth into the fluid stream, typically  $\frac{1}{8}$  of the pipe I.D., which has been proven to be the nominal velocity point when symmetrical flow profiles are present. This assumption requires the probe to be downstream of any piping condition (elbows, valves, thermowells, tees, etc.) that can cause flow abnormalities. Typically, a minimum of 15 pipe diameters of straight pipe is required to develop a symmetrical flow profile.

Figure 1 – Magnet Excitation

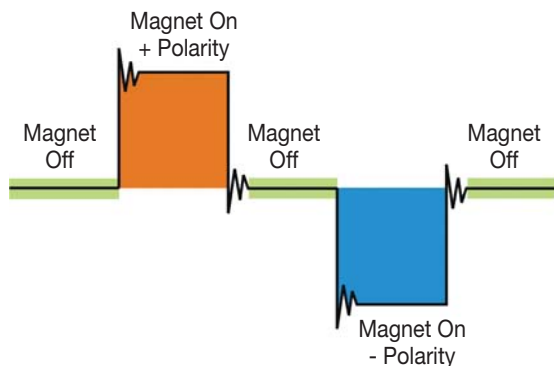
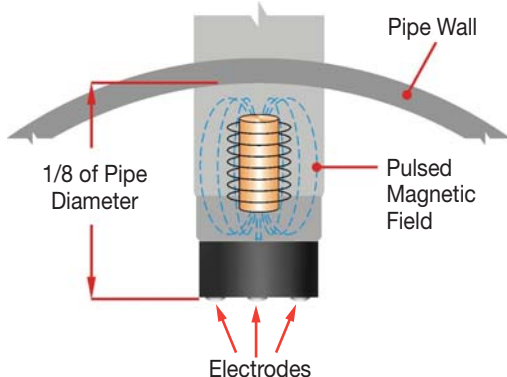

Figure 2 – MagProbe Design



The MFX is the perfect alternative to clamp-on and inline style flow meters where pipe construction and site accessibility may present an installation problem. Dynasonics' "hot-tap" design makes installation of the MagProbe sensor possible without having to plumb in or drain a line.

A typical application would find the MagProbe installed on a pipe inside a vault or manhole (See Figure 3), measuring the flow of water or wastewater. The Type 4X enclosure rating of the MFX transmitter gives the added flexibility of indoor or outdoor usage.

The MFX is best suited for measuring clean liquids on large pipes with large amounts of straight run.

Figure 3 – Typical MagProbe Water Application

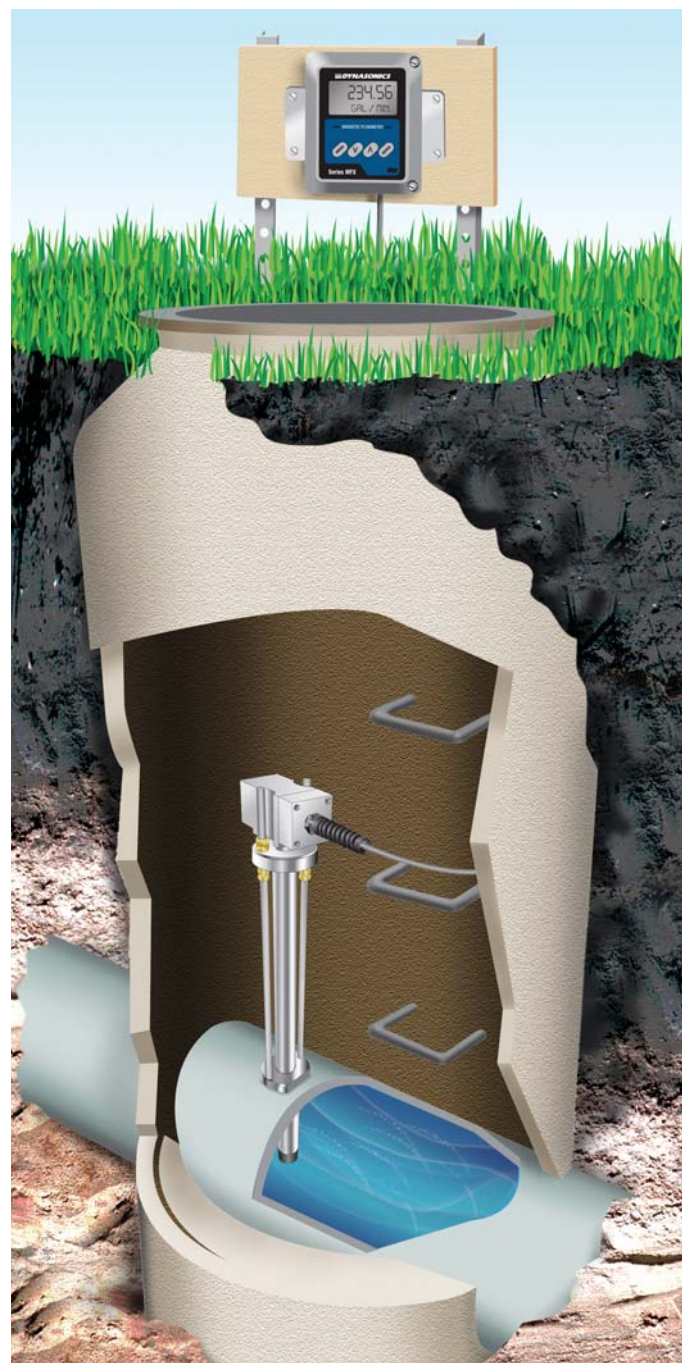

## SPECIFICATIONS

### TRANSMITTER

DESCRIPTION	SPECIFICATION
<b>Power Requirements</b>	115/230 VAC 50/60 Hz $\pm$ 15% @ 5 VA max.; 9-28 VDC @ 3 VA max.
<b>Velocity Range</b>	-30 to +30 FPS (-9 to +9 MPS); minimum flow 0.1 FPS (0.03 MPS)
<b>Inputs/Outputs</b>	All modules are optically isolated from earth and system grounds. Only one module may be installed.
<b>Optional</b>	<b>4-20 mA Output</b> 800 Ohms max.; 12-bit resolution; internal or external power; can be spanned anywhere in the velocity range <b>Relay</b> two separate Form C relays, 200 VAC @ 0.5 A resistive max. <b>Rate Pulse</b> 0-2,500 Hz; 0.21 Ohm resistance; 1 A max.; can be spanned anywhere in the velocity range <b>RS232C</b> data rate to 57.6K <b>RS485</b> supports up to 126 drops on three wires; 57.6K max. baud; Communications protocol <b>Data Logger</b> 200,000 point, 16-bit resolution; integral DB-9 connector for plugging into PC; can be removed and installed without disconnecting system power
<b>Display</b>	2-line $\times$ 8-character LCD, back lit. Top row: 7-segment digit height 0.7 inches (18 mm), Bottom row: 14-segment digit height 0.35 inches (9 mm); 8-digit rate, 8-digit totalizer (resettable)
<b>Units:</b>	User configured
<b>Engineering units</b>	Feet, gallons, cubic feet, mil-gal, (42 Gallon and 31.5 Gallon) barrels, acre-feet, lbs., meters, cubic meters, mil-liters, kg
<b>Rate time intervals</b>	Seconds, minutes, hours and days
<b>Temperature Range</b>	-40 °F to +185 °F (-40 °C to +85 °C), 0-95% relative humidity, non-condensing
<b>Enclosure</b>	Type 4X (IP-65), polycarbonate, SS, brass and plated steel. 7.00H $\times$ 5.75W $\times$ 3.88D inches (178H $\times$ 146W $\times$ 99D mm)
<b>Accuracy Flow Rate</b>	$\pm$ 2% of reading at rates greater than 1 FPS (0.3 mps); $\pm$ 0.02 FPS (0.006 mps) at rates less than 1 FPS (0.3 mps)
<b>Sensitivity</b>	$\pm$ 0.005 FPS ( $\pm$ 0.0017 MPS)
<b>Response Time</b>	3-300 seconds, user configured, to 100% of value, step change in flow
<b>Security</b>	Keypad lockout, access code enable
<b>Approvals</b>	(Std) General Purpose

### PROBE

DESCRIPTION	SPECIFICATION
<b>Pipe Sizes</b>	Internal diameters 4 to 120 inches (102 to 3048 mm); requires 1-1/2" NPT port
<b>Liquid Requirements</b>	Liquids with conductivity > 10 micro-Siemen/cm; liquids with solids that will not coat or wrap around the probe tip
<b>Transmitter to Probe Distance</b>	Up to 990 feet (297 meters)
<b>Environment</b>	-40 °F to +225 °F (-40 °C to +105 °C), NEMA 6 (IP67) submersible
<b>Materials of Construction</b>	316 Stainless Steel, PVDF, Viton <sup>®</sup> , PVC jacketed cable rated for outdoor and direct-burial use Electrodes: Titanium
<b>Operating Pressure</b>	Up to 700 PSIG (48 bar) max. @ +75 °F (+25 °C)



## ISO-MOD INPUT/OUTPUT MODULES



### General

ISO-MODs are epoxy-encapsulated electronic output modules that are simple to install and replace in the field. All modules are 2500 V optically isolated from MFX power and earth grounds – eliminating the potential for ground loops and reducing the chance of severe damage in the event of an electrical surge. Six ISO-MOD options are available including: 4-20 mA output, dual-relay, rate pulse, RS232C, RS485 and 200K-point data logger. All modules are field-configurable by utilizing the front keypad. Field wiring connections to ISO-MODs are quick and easy using pluggable terminals. Features of the various ISO-MODs are described below.

### 4-20 mA Output Module

Easily configured via jumper selections into either an internally-powered or externally-powered mode, the 4-20 mA Output Module interfaces with virtually all recording and logging systems by transmitting an analog current signal that is proportional to system flow rate. Independent 4 mA and 20 mA span settings are established in software. These settings can span negative and positive flow directions to output bi-directional flow data. These entries can be set anywhere in the -30 to +30 FPS (-9 to +9 MPS) measuring range of the instrument. Output resolution of the module is 12-bits (4096 discrete points) and because of its low insertion loss characteristics (less than 5 V typical), the module can drive up to 800 Ohms of load with a 24 V power source.

### Rate Pulse Output Module

The Rate Pulse Output Module is utilized to transmit information to external counters and PID systems via a frequency output that is proportional to system flow rate. Independent Zero and Span settings are established in software. These entries can be set anywhere in the -30 to +30 FPS (-9 to +9 MPS) measuring range of the instrument. Output resolution of the module is 12-bits (4096 discrete points) and the maximum output frequency setting is 2500 Hz.

Two electronic outputs are integrated into the module – an open-drain MOSFET and a turbine meter simulated type. The MOSFET has an ON resistance of 0.21 Ohms and is rated at 1 A and 100 V. The turbine simulation permits the instrument to transmit information to devices configured for magnetic turbine and paddle-wheel flow meter pickups.

### RS232C Input/Output Module

The RS232C Module can be interfaced with serial communication ports of PCs, PLCs and SCADA systems, running a Modbus protocol, that are used to monitor flow rate information in piping systems. Baud rates up to 57.6K are supported.

### RS485 Input/Output Module

The RS485 Module allows up to 126 MFX systems to be placed on a single three-wire cable network. All meters are assigned a unique serial number that allows all of the meters on the cable network to be accessed independently. Baud rates up to 57.6K and cable lengths to 5,000 feet (1,500 meters) are supported.

### Control Relay Module

Two independent SPDT (single-pole, double-throw, Form C) relays are contained in this module. The relay operations are user configured via software to act in either a flow rate alarm, system diagnostic alarm or totalizer/batching mode. The relays are rated for 200 VAC max. and have a current rating of 0.5 A resistive load (175 VDC @ 0.25 A resistive). It is highly recommended that a secondary relay be utilized whenever the Control Relay ISO-MOD is used to control inductive loads such as solenoids and motors.

### Data Logger Module

This powerful 200,000-point data logger/electronic stripchart recorder configures to match user applications. The logger stores time-stamped, high resolution (16-bit) data at user-selected intervals ranging from 1 to 1,000 seconds. Configuration of and data retrieval from the logger can be accomplished in one of two ways:

- The module can be carried back to the office and plugged into a serial port on a PC via the module's integral DB-9 connector. This feature eliminates the need to carry a laptop computer to the flow meter site.
- A hardwire connection can be made to the data logger module which allows direct interface to the serial communication port of a PC, PLC or SCADA system. Historical data can be uploaded via the supplied Windows® - based software utility.

# Series MFX

## DIMENSIONAL SPECIFICATIONS

### MECHANICAL DIMENSIONS: INCHES (mm)

#### WALL MOUNT

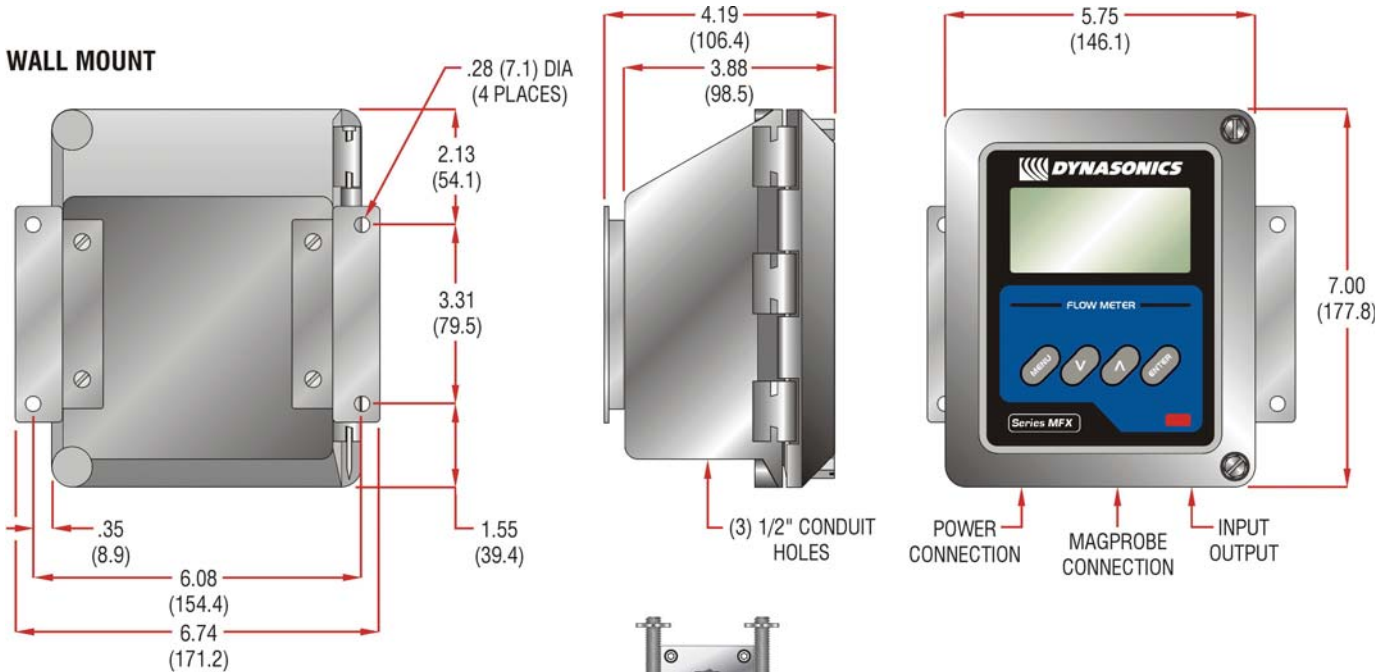

#### PANEL MOUNT (optional)

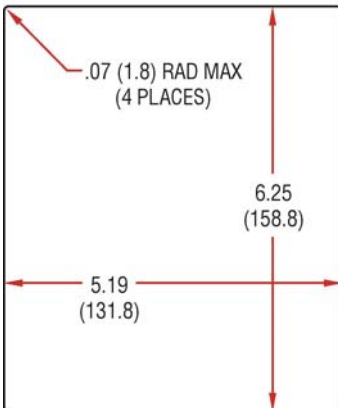

#### PANEL CUT-OUT

PANEL THICKNESS:  
0.5" (12 mm) MAX

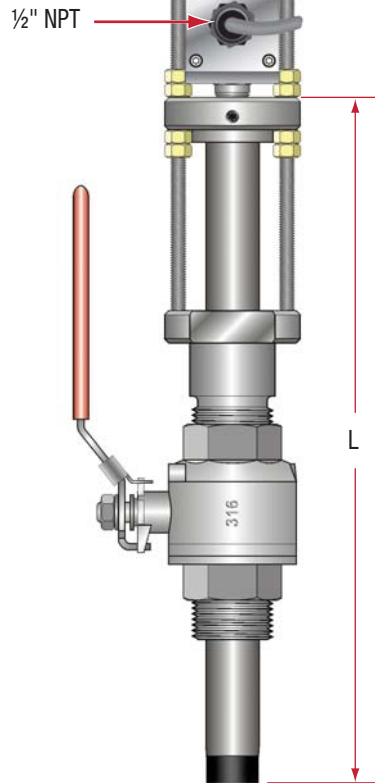

#### HEAD-ON VIEW OF PIPE

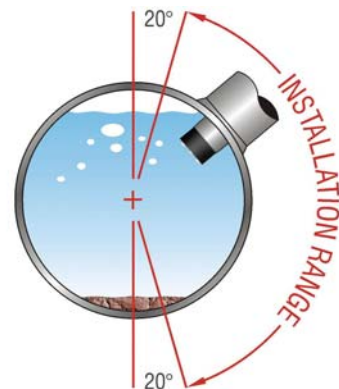

INSTALL MAGPROBE  
BETWEEN 1 O'CLOCK  
AND 5 O'CLOCK ON THE PIPE

MODEL	LENGTH (L)
DMP 2	19.72 (501)
DMP 3	29.72 (755)
DMP 4	39.72 (1009)
DMP 5	49.72 (1263)

DYNASONICS is a registered trademark of Racine Federated Inc.  
MagProbe and Ultralink are trademarks of Racine Federated Inc.  
UL is a registered trademark of Underwriters Laboratories.  
VITON is a registered trademark of DuPont Dow Elastomers.  
WINDOWS is a registered trademark of Microsoft Corp.  
© 2009 Racine Federated Inc., all rights reserved.

FORM MFX 12/09

**DYNASONICS**

8635 Washington Ave. ■ Racine, WI 53406-3738 ■ USA  
Tel: 262.639.6770 800.535.3569 US & Canada  
Fax: 262.639.2267 800.732.8354 US & Canada  
www.dynasonics.com dynasonics\_sales@racinefed.com

**RFI** Racine Flow Meter Group

**Blancett**

**DYNASONICS Flo-tech**

**HEDLAND**

**PRESO**

**racine**